

# MODEL 700SB

## MEDIUM DUTY SLIDER BED BELT CONVEYOR

24 HOUR SHIPMENTS INCLUDE ALL 1-FOOT INCREMENTS 5'-0" TO 100'-0"



Conveyor shown with optional supports

Slider bed belt conveyors remain the most popular of all powered conveyors, providing an economical means of transporting goods for packing, testing, inspecting and various assembly line operations

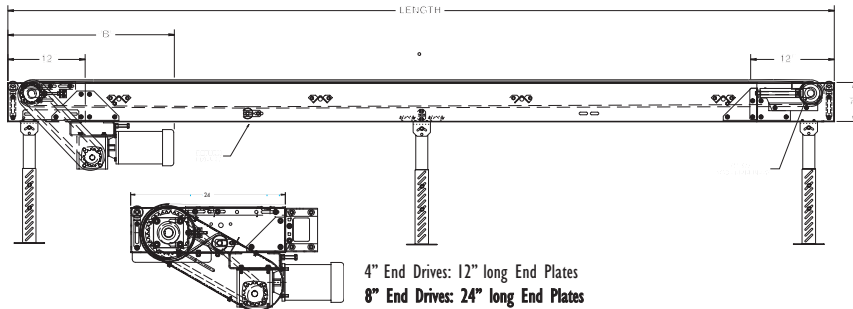
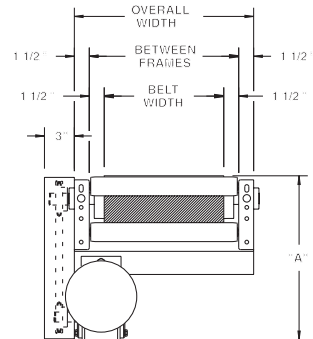

HP @ 60 FPM	"A" MAX		"B" MAX	
	4" DRV.	8" DRV.	4" DRV.	8" DRV.
1/3	16-5/8"	16-5/8"	27-3/32"	33-3/32"
1/2	16-5/8"	16-5/8"	27-3/32"	33-3/32"
3/4	17"	17"	27-23/32"	33-23/32"
1	17-1/4"	17-1/4"	28-15/32"	34-15/32"
1-1/2	18-1/8"	18-1/8"	31-3/32"	37-3/32"
2	19"	19"	32-3/32"	38-3/32"

### SPECIFICATIONS

**BELTING:** PVC-120 black.

**DRIVE PULLEY:** 4" dia. with 1-3/16" dia. shaft or 8" dia. with 1-7/16" dia. shaft, both machine crowned and fully lagged.

**TAIL PULLEY:** 4" dia., machine crowned, with 1-3/16" dia. shaft.

**END DRIVE:** Allows one-direction (unit) operation; add optional center drive for reversible application.

**TAKE-UP:** Screw type unit at tail pulley provides 12" belt take-up.

**SAFETY POP-OUT ROLLER:** Standard on both ends, 1.9" dia. x 16 ga. steel roller, model 196S.

**BEARINGS:** All pulley bearings are precision, heavy duty, lubricated, ball bearing units with cast iron housings.

**BED:** 7" x 1-1/2" x 12 ga. channel frame with 14 ga. slider bed 9"-39" BF; 12 ga. bed 33" BF and above with bed pan braces.

**BELT SPEED:** 60 FPM, constant.

**MOTOR DRIVE:** 1/3 HP, 230/460/3, 60 cycle, ODP right angle gear motor.

**ROLLER CHAIN:** Drive pulley is driven by No. 50 roller chain for 1-1/2 HP or less and No. 60 chain on larger drives. Chain take-up provided on motor base.

**RETURN ROLLERS:** 1.9" dia. x 16 ga. steel, model 196S, adjustable.

**ELECTRICAL CONTROLS:** Optional.

### WARNING

Prevent pinch points that exist when belt conveyors are permanently attached to other conveyors or equipment!



■ 24 hour shipment ■ 2 week shipment

**SPECIFICATION TABLE**

50'-0" lengths and under are equipped with 4" dia. drive pulley; over 50'-0" includes 8" dia. drive pulley

CONVEYOR LENGTH		5'	10'	15'	20'	25'	30'	35'	40'	50'	60'	70'	80'	90'	100'
BELT	BF	Unit weights (lbs.)													
6"	9"	244	265	311	331	374	395	437	459	526	591	656	720	784	848
12"	15"	268	299	355	386	442	473	529	560	654	741	830	917	1004	1091
18"	21"	314	369	451	506	587	642	724	779	926	1062	1211	1337	1473	1610
24"	27"	366	422	502	568	662	728	821	887	1059	1209	1382	1541	1701	1860
30"	33"	N/A	434	535	608	709	782	879	956	1146	1300	1497	1670	1846	2020
36"	39"	N/A	476	591	677	793	879	990	1080	1301	1477	1707	1908	2112	2313

**OPTIONAL EQUIPMENT**

**BELTING:** Black PVC ruff-top; 3-ply brown neoprene ruff-top; PVC-120 white food grade COS; PVC-150 black COS; 3-ply CN 40 urethane cover. Consult factory for other belting.

**CENTER DRIVE:** Reversible drive with integral belt take-up of 24". Specify location. Center drive option available on units 6'-0" long and above.

**SIDE MOUNTED END DRIVE:** Provides minimum conveyor height of 10" TOB (4" dia. drive pulley); 12" TOB (8" dia. drive pulley).

**OVERHEAD END DRIVE:** Provides minimum conveyor height of 8" TOB (4" dia. drive pulley); 10" TOB (8" dia. drive pulley).

**NOSE-OVER:** Provides smooth transition from incline to horizontal position. Single nose-over adjusts 0-20°; double nose-over adjusts 0-35°. Feeders also available. See Power Accessories.

**AUXILIARY TAKE-UP:** Provides 24" of belt take-up. Specify location. See Power Accessories.

**SIDE TABLES:** Available in 9", 15" and 21" widths (14 ga.) one or both sides. See Power Accessories.

**UNDERTRUSSED BED:** Available to provide clearance underneath unit at bed joint locations. Specify location for undertrussing and desired clearance underneath unit. Consult factory.

**CEILING HANGERS:** 5/8" dia. threaded rod with hardware to attach rods to conveyor. Provides 6' clearance between ceiling and TOB (furnished in place of floor supports). See Conveyor Accessories.

**BELT SPEED:** Constant speed 10-120 FPM; DC variable speed; AC inverter variable speed. Other constant or variable speeds available. **NOTE: CAPACITY CHANGES WITH SPEED.**

**FLOOR SUPPORTS:** Supports, knee braces, casters and polytief supports available. See Conveyor Accessories.

**GUARD RAILS:** 1-3/4" x 1" formed channel (model GC), adjusts horizontally to 10" wider than belt and vertically to 6" above belt; formed steel fixed (model FSG in 2", 4", 6", 8", 12", and 18" heights; fixed channel (model FC); 1-1/2" angle (model GA1-1/2). See Conveyor Accessories.

**MOTORS:** Available through 3 HP in TEFC, explosion proof, dirty duty, brake motor, 115/230/1, 575/3, etc.

**ELECTRICAL CONTROLS:** Magnetic starter (one direction or reversible); One direction manual starter; Momentary start/stop push button station; Forward/reversing /stop push button station. Mounting and pre-wiring for units up to 12' long.



**OPTIONAL DC VARIABLE SPEED CONTROLLER**



**OPTIONAL CENTER DRIVE**