

MODEL 796RB

MEDIUM DUTY ROLLER BED BELT CONVEYOR

24 HOUR SHIPMENTS INCLUDE ALL 1-FOOT INCREMENTS 5'-0" TO 100'-0"



Conveyor shown with optional supports

Model 796RB, medium duty roller bed belt conveyor, is well suited for transporting unit loads with lesser horsepower requirements than slider bed belt conveyors.

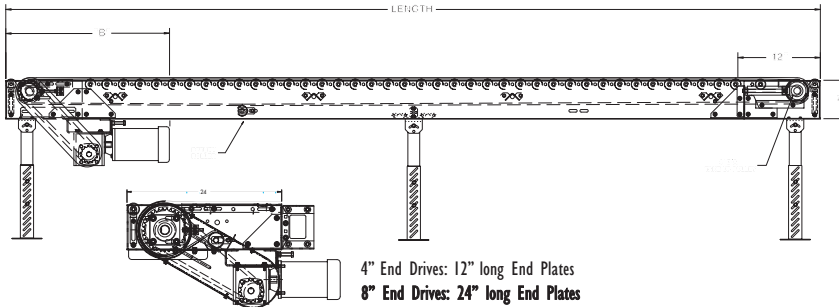
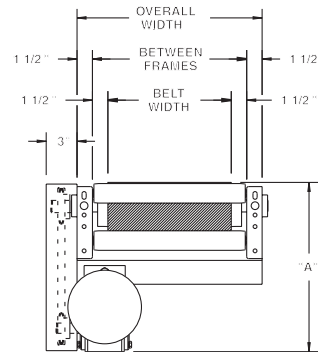

HP @ 60 FPM	"A" MAX		"B" MAX	
	4" DRV.	8" DRV.	4" DRV.	8" DRV.
1/3	16-5/8"	16-5/8"	27-3/32"	33-3/32"
1/2	16-5/8"	16-5/8"	27-3/32"	33-3/32"
3/4	17"	17"	27-23/32"	33-23/32"
1	17-1/4"	17-1/4"	28-15/32"	34-15/32"
1-1/2	18-1/8"	18-1/8"	31-3/32"	37-3/32"
2	19"	19"	32-3/32"	38-3/32"

SPECIFICATIONS

BELTING: PVC-120 black.

CARRIER ROLLERS: 1.9" dia. x 16 ga. steel rollers, model 196S.

DRIVE PULLEY: 4" dia. with 1-3/16" dia. shaft or 8" dia. with 1-7/16" dia. shaft, both machine crowned and fully lagged.

TAIL PULLEY: 4" dia., machine crowned, with 1-3/16" dia. shaft.

END DRIVE: Allows one-direction (unit) operation; add optional center drive for reversible application.

SAFETY POP-OUT ROLLER: Standard on both ends, 1.9" dia. x 16 ga. steel roller, model 196S.

SQUARING RODS: Adjustable rods on underside of bed allow frame to be squared for improved belt tracking and are standard on all units over 30'.

BED: 7" x 1-1/2" x 12 ga. channel frame. Bed sections attached with couplings and floor supports.

BEARINGS: All pulley bearings are precision, heavy duty, lubricated, ball bearing units with cast iron housings.

TAKE-UP: Screw type unit at tail pulley provides 12" belt take-up.

BELT SPEED: 60 FPM, constant.

RETURN ROLLERS: 1.9" dia. x 16 ga. steel, model 196S, adjustable.

ROLLER CHAIN: Drive pulley is driven by No. 50 roller chain for 1-1/2 HP or less and No. 60 chain on larger drives. Chain take-up provided on motor base.

MOTOR DRIVE: 1/3 HP, 230/460/3, 60 cycle, ODP right angle gear motor.

ELECTRICAL CONTROLS: Optional.

WARNING

Prevent pinch points that exist when belt conveyors are permanently attached to other conveyors or equipment!



■ 24 hour shipment ■ 2 week shipment

SPECIFICATION TABLE

50'-0" lengths and under are equipped with 4" dia. drive pulley; over 50'-0" includes 8" dia. drive pulley

CONVEYOR LENGTH			5'	10'	15'	20'	25'	30'	40'	50'	60'	70'	80'	90'	100'
BELT	BF	OAW	Unit weights (lbs.) with 3" roller centers (For other centers, deduct weights below)												
12"	15"	18"	339	455	591	693	830	931	1169	1407	1645	1883	2121	2359	2598
18"	21"	24"	396	516	675	795	954	1074	1353	1632	1911	2190	2469	2748	3028
24"	27"	30"	443	595	712	934	1121	1273	1612	1951	2290	2629	2968	3307	3647
30"	33"	36"	N/A	663	875	1057	999	1451	1841	2239	2633	3027	3421	3815	4210
36"	39"	42"	N/A	730	978	1183	1429	1636	2089	2542	2995	3448	3901	4354	4808
42"	45"	48"	N/A	832	1140	1398	1706	1964	2530	3101	3662	4228	4794	5360	5927
48"	51"	54"	N/A	934	1302	1615	1983	2296	2977	3658	4339	5020	5701	6382	7064

Deduct the following weights (lbs.) for other than 3" centers

ROLLER CENTERS	12" BELT		18" BELT		24" BELT		30" BELT		36" BELT		42" BELT		48" BELT	
	Per 5'	Per 10'	Per 5'	Per 10'	Per 5'	Per 10'	Per 5'	Per 10'	Per 5'	Per 10'	Per 5'	Per 10'	Per 5'	Per 10'
4-1/2"	-15	-30	-20	-40	-25	-50	-30	-60	-35	-70	-40	-80	-45	-90
6"	-30	-60	-40	-80	-50	-100	-60	-120	-70	-140	-80	-160	-90	-180
9"	-42	-78	-56	-104	-70	-130	-84	-156	-98	-182	-112	-208	-99	-234
12"	-45	-90	-60	-120	-75	-150	-90	-180	-105	-210	-120	-240	-135	-270

OPTIONAL EQUIPMENT

BELTING: Black PVC ruff-top; 3-ply brown neoprene ruff-top; PVC-120 white food grade COS; PVC-150 black COS; 3-ply CN 40 urethane cover. Consult factory for other belting.

CENTER DRIVE: Reversible drive with integral belt take-up of 24". Specify location. Center drive option available 6'-0" long units & above.

SIDE MOUNTED END DRIVE: Provides minimum conveyor height of 10" TOB (4" dia. drive pulley); 12" TOB (8" dia. drive pulley).

OVERHEAD END DRIVE: Provides minimum conveyor height of 8" TOB (4" dia. drive pulley); 10" TOB (8" dia. drive pulley).

AUXILIARY TAKE-UP: Provides 24" of belt take-up. Specify location. See Power Accessories.

SIDE TABLES: Available in 9", 15" and 21" widths (14 ga.) one or both sides. See Power Accessories.

FLOOR SUPPORTS: Supports, knee braces, casters and polytyr supports available. See Conveyor Accessories.

CEILING HANGERS: 5/8" dia. threaded rod with hardware to attach rods to conveyor. Provides 6' clearance between ceiling and TOB (furnished in place of floor supports). See Conveyor Accessories.

UNDERTRUSSED BED: Available to provide clearance underneath unit at bed joint locations. Specify location for undertrussing and desired clearance underneath unit. Consult factory.

BELT SPEED: Constant speed 10-120 FPM; DC variable speed; AC inverter variable speed. Other constant or variable speeds available. **NOTE: CAPACITY CHANGES WITH SPEED.**

MOTORS: Available through 3 HP in TEFC, explosion proof, dirty duty, brake motor, 115/230/1, 575/3, etc.

NOSE-OVER: Provides smooth transition from incline to horizontal position. Single nose-over adjusts 0-20°; double nose-over adjusts 0-35°. See Power Accessories.

GUARD RAILS: 1-3/4" x 1" formed channel (model GC), adjusts horizontally to 10" wider than belt and vertically to 6" above belt; formed steel fixed (model FSG in 2", 4", 6", 8", 12", and 18" heights; fixed channel (model FC); 1-1/2" angle (model GA1-1/2). See Conveyor Accessories.

ELECTRICAL CONTROLS: Magnetic starter (one direction or reversible); One direction manual starter; Momentary start/stop push button station; Forward/reversing /stop push button station. Mounting and pre-wiring for units up to 12' long.

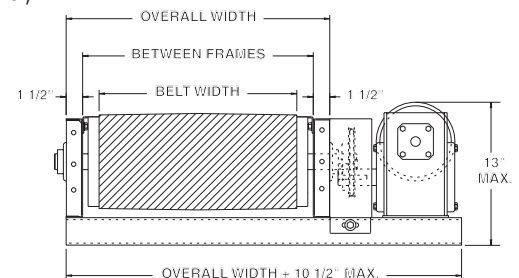

OPTIONAL SIDE MOUNTED DRIVE

