

# MODEL IPT HEAVY DUTY INDEXING POWERED TURNTABLE

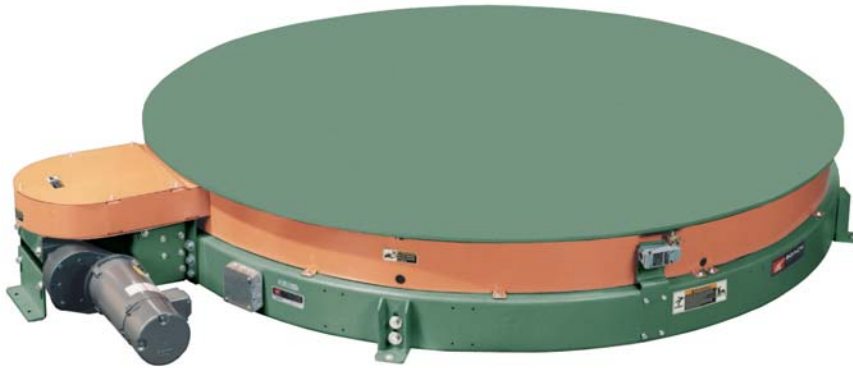

Indexing powered turntables convey heavy unit loads in numerous applications. A heavy duty chain driven live roller may be mounted on turntable platform and rotated to orient product at specified intervals allowing operator to perform a variety of tasks.

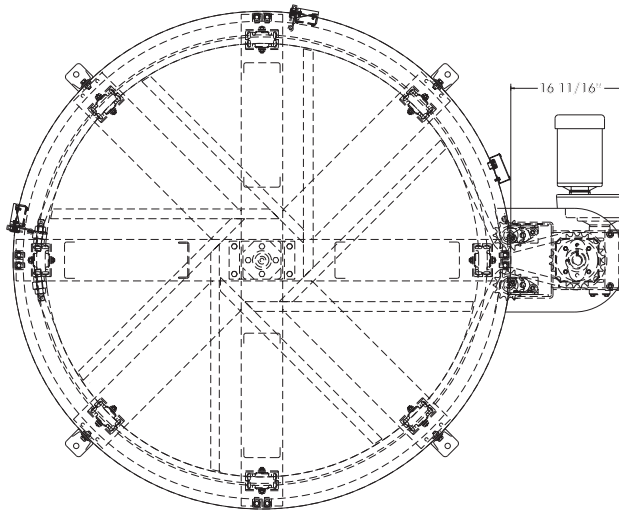

## SPECIFICATIONS

**ROTATION:** 2 position, 3 position or 4 position.

**SPEED:** 35 FPM at outside diameter.

**CHAIN DRIVE:** No. 80 roller chain.

**CHAIN GUARD:** The chain drive is completely enclosed.

**CASTERS:** (8) 4" dia. heavy duty rubber-covered casters support rotation of turntable carrier platform.

**DIAMETER:** 3'-0", 3'-6", 4'-0", 4'-6", 5'-0", 5'-6", 6'-0", 6'-6", 7'-0", 7'-6" and 8'-0" dia.

**CARRIER PLATFORM:** 3" structural platform with 1/2" thick steel plate supported by heavy duty casters.

**BEARINGS:** Heavy duty ball bearing 4-hole flange.

**CAPACITY:** 4000 lbs. max. product load.

**MOTOR DRIVE:** 3/4 HP, 230/460/3, 60 cycle, ODP right angle gear motor with brake.

**ELEVATION:** Minimum 12-1/2" to top of plate with (4) structural leveling supports.

**ELECTRICAL CONTROLS:** Limit switches supplied as follows: 2 position = 2 limit switches; 3 position = 3 limit switches; 4 position = 4 limit switches.

## SPECIFY MODEL NUMBER PER EXAMPLE

**IPT-72-2**

IPT-(diameter)-(stop positions)

Diameter available in 36", 42", 48", 54", 60", 66", 72", 78", 84", 90" and 96".

Number of stop positions is 2, 3 or 4.

MINIMUM CONVEYOR DISTANCE IS 45  
ON EITHER SIDE OF TURNTABLE DRIVE:  
TURNTABLE IS CAPABLE OF 45 INTERVALS

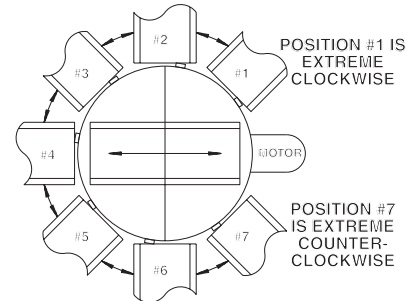

GENERIC REFERENCE FOR STANDARD  
LIMIT SWITCH MOUNTED POSITIONS

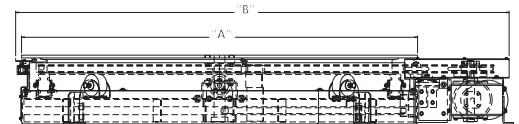

12-1/2" Minimum Height

"A"	"B"	WEIGHT (lbs.)
3'-0"	53-3/4"	718
3'-6"	59-3/4"	814
4'-0"	65-3/4"	926
4'-6"	71-3/4"	1037
5'-0"	77-3/4"	1158
5'-6"	83-3/4"	1285
6'-0"	89-3/4"	1421
6'-6"	95-3/4"	1564
7'-0"	101-3/4"	1718
7'-6"	107-3/4"	1877
8'-0"	113-3/4"	2045

## OPTIONAL EQUIPMENT

**ELEVATION:** Other height elevations to top of plate available; consult factory.

**MOTORS:** Available through 2 HP in TEFC, explosion proof, dirty duty, 115/230/1, 575/3, etc.

**ELECTRICAL CONTROLS:** Manual start/stop push button switch; magnetic starter; photo relay; others available.



■ 6 week shipment