

# MODEL SZ196ZPA SMART ZONE® MEDIUM DUTY ZERO PRESSURE LIVE ROLLER ACCUMULATOR



Conveyor shown with optional supports

Roach SZ196ZPA SMART ZONE® safely accumulates packages with zero back pressure utilizing zone singulation operation. Loads up to 125 lbs./ft. may be effectively handled with its unique design. This conveyor features NO minimum weight limitations. Roach SMART ZONE® replaces sensor rollers with photo electric sensors to accumulate products with previously difficult minimal weight restrictions and is easy to install.

## SMART ZONE:

Retroreflective photo eyes includes 110V AC or 24V DC power supply.

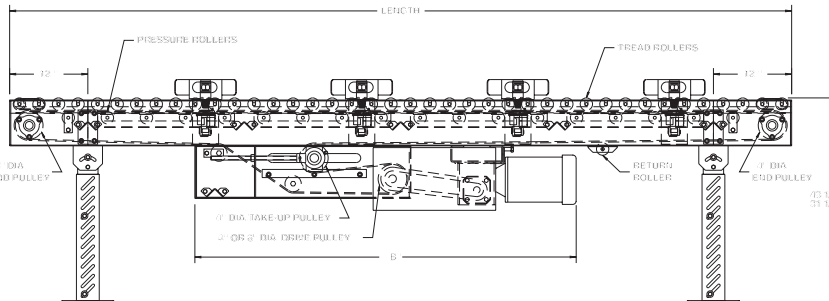
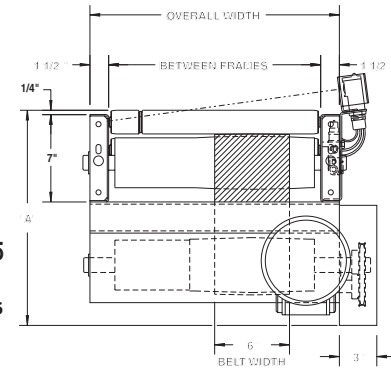

HP @ 60 FPM	"A" MAX		"B" MAX	
	4" DRV.	8" DRV.	4" DRV.	8" DRV.
1/3	16-5/8"	17-5/8"	58-5/32"	58-5/32"
1/2	16-5/8"	17-5/8"	58-5/32"	58-5/32"
3/4	17"	17-5/8"	58-25/32"	58-25/32"
1	17-1/4"	17-5/8"	59-17/32"	59-17/32"
1-1/2	18-1/8"	18-1/8"	61-21/32"	61-21/32"
2	19"	19"	62-21/32"	62-21/32"

## SPECIFICATIONS

**TREAD ROLLERS:** 1.9" dia. x 16 ga. steel, model 196S.

**PRESSURE ROLLERS:** 1.9" dia. x 16 ga. steel, model 196S; 8" BF with 6" wide belt.

**BELTING:** 6" wide black PVC-120 COS.

**DRIVE PULLEY:** 4" dia. with 1-3/16" dia. shaft or 8" dia. with 1-7/16" dia. shaft, both crowned and fully lagged.

**END PULLEY:** 4" dia., crowned, with 1-3/16" dia. shaft.

**RETURN ROLLERS:** 1.9" dia. x 16 ga. steel, model 196S, adjustable.

**BEARINGS:** All pulley bearings are precision, heavy duty, lubricated, ball bearing units with cast iron housings.

**SPEED:** 60 FPM, constant.

**ACCUMULATION:** Zone singulation operation; 2'-0" long zones. 1'-0" of live roller over end plates at each end of conveyor remains "live" during operation (# of zones x zone length + 2' = overall conveyor length). Zones are pneumatically actuated using photo electric sensors.

**BED:** 7" x 1-1/2" x 12 ga. channel frame slotted for tread rollers to pop-out. When unit is installed at 7'-0" elevation or higher, rollers must be retained in conveyor frame. Specify desired elevation. Bed sections attached with couplings and floor supports.

**FRL:** Unit is provided with filter, I regulator, lubricator with 1/4" ports.

**PNEUMATIC ACTUATION:** Maximum air line pressure should not exceed 30 PSI.

**SQUARING RODS:** Adjustable rods on underside of bed allow frame to be squared for improved belt tracking and are standard on all units over 30'.

**MOTOR DRIVE:** 1/3 HP, 230/460/3, 60 cycle, ODP right angle gear motor.

**ROLLER CHAIN:** Drive pulley is driven by No. 50 roller chain for 1-1/2 HP or less and No. 60 chain on larger drives. Chain take-up provided on motor base.

**ELECTRICAL CONTROLS:** Optional



## WARNING

Pop-out rollers should be retained in frame if unit is elevated to 7'-0" and above.

■ 3 week shipment

**SPECIFICATION TABLE**

50'-0" lengths and under are equipped with 4" dia. drive pulley; over 50'-0" includes 8" dia. drive pulley

CONVEYOR LENGTH			6'	10'	15'	20'	25'	30'	40'	50'	60'	70'	80'	90'	100'
BF	OAW	BELT	Unit weights (lbs.) with 3" roller centers (For other centers, deduct weights below)												
15"	18"	6"	446	553	722	856	1025	1159	1462	1765	2068	2371	2674	2977	3280
19"	22"	6"	478	600	782	934	1123	1270	1600	1934	2274	2595	2925	3255	3590
21"	24"	6"	511	645	847	1015	1217	1385	1755	2125	2495	2865	3235	3605	3975
25"	28"	6"	557	709	939	1132	1358	1543	1963	2370	2780	3193	3608	4020	4458
27"	30"	6"	579	738	977	1176	1415	1614	2052	2490	2928	3366	3804	4242	4680
33"	36"	6"	650	828	1107	1296	1613	2232	2700	3168	3638	4104	4572	5040	5508
39"	42"	6"	717	928	1237	1501	1810	2692	2971	3538	4111	4684	5257	5830	6403

Deduct the following weights (lbs.) for other than 3" centers

TREAD ROLLER CENTERS	15" BF		19" BF		21" BF		25" BF		27" BF		33" BF		39" BF	
	Per 5'	Per 10'	Per 5'	Per 10'	Per 5'	Per 10'	Per 5'	Per 10'	Per 5'	Per 10'	Per 5'	Per 10'	Per 5'	Per 10'
4"	-23	-45	-28	-55	-30	-60	-35	-69	-37	-75	-45	-90	-53	-105
6"	-45	-90	-54	-108	-60	-120	-69	-138	-75	-150	-90	-180	-105	-210

**OPTIONAL EQUIPMENT**

**ACCUMULATION:** 30" and 60" zones available in 3" and 6" roller centers; 40" and 60" zones available in 4" roller centers.

**SLUG RELEASE:** Products may be slug released rather than individual product release in normal zone singulation; accumulation mode will not be disturbed when slug release option utilized.

**BELTING:** 6" wide black PVC-150; 12" wide PVC-120.

**END DRIVE:** Mounted underneath conveyor. Minimum possible height is 20" TOR for underneath mounted end drive. Belt take-up required for end drive (if substituting end drive for center drive).

**AUXILIARY TAKE-UP:** Provides 24" of belt take-up; specify location. See Power Accessories.

**FLOOR SUPPORTS:** Supports, knee braces, casters and polytier supports available. See Conveyor Accessories.

**CEILING HANGERS:** 5/8" dia. threaded rod with hardware to attach rods to conveyor. Provides 6' clearance between ceiling and TOR (furnished in place of floor supports). See Conveyor Accessories.

**GALVANIZED ROLLERS:** Both tread and pressure rollers available in galvanized steel, model 196G. Specify tread only or both tread and pressure rollers.

**192S TREAD ROLLERS:** 1.9" dia. x 12 ga. steel tread rollers, model 192S, available in model SZ192ZPA SMART ZONE®.

**SPEED:** Constant speed 15-120 FPM; DC variable speed; AC inverter variable speed. Other constant or variable speeds available. **NOTE: CAPACITY CHANGES WITH SPEED.**

**MOTORS:** Available through 3 HP in TEFC, explosion proof, dirty duty, brake motor, 115/230/1, 575/3, etc.

**DEFUSED SMARTZONE:** Photoeyes mounted below tread rollers.



**PHOTO SENSOR MOUNT**